

SQUARE DOWNLIGHT

PQ-DWSQB-008P

- Direct lighting design, all the shell is a big heat sink, big dissipation area, excellent thermal performance.
- High conductive aluminum PCB board helps extend the lifetime of the LED
- 30-50% more brightness compared with side lighting LED panel light
- High brightness, soft and uniform lighting effect, slow light decline
- No UV, no IR , no glare, no harms to eyes and environmental friendly



LISTINGS



SPECIFICATIONS

Input Voltage	AC85-265/50-60HZ	Beam Angle	120°
Input Power	18W	Color Temperature	2700-3200K, 4000-4500K, 5700-6200K
Lumen	1260lm	Working Temp.	-25°+50°
Efficiency	70LM/W	Shell Temp	<30°
CRI	>70	Function	Dimmable or Non-dimmable
Power Factor	>0.9	Appearance color	White
LED Chip	SMD3528	Product size	φ215mm*215mm
Qty/ Ctn	3PCS	Cutout Size	φ200mmx200mm
Warranty	5 years	Certification	CE , UL, ROHS

SQUARE DOWNLIGHT

PQ-DWSQB-008P

DIMENSIONS

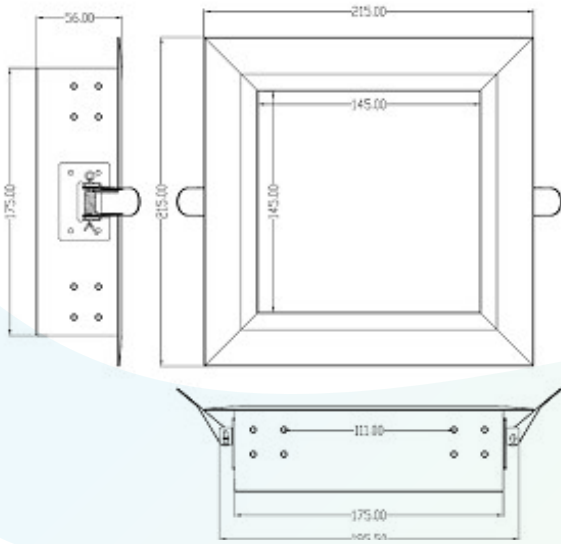

CUTOUT SIZE

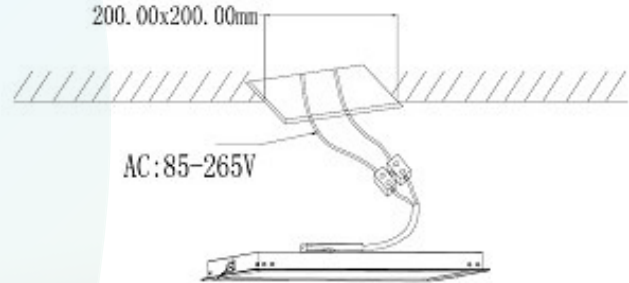

INSTALLATION

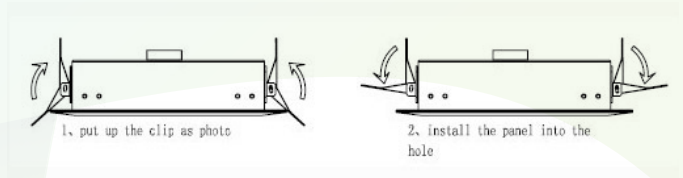

LIGHT DISTRIBUTION

