

# PROJECTEUR

## PQ-FLX



EMPLACEMENT HUMIDE



PUISSANCE RÉGLABLE



PROJECTEUR					
Modèle	Température de Couleur (CCT)	Puissance (W)	Tension d'Entrée (V)	Options	Montage
PQ-FLX	CCTK = 3000K/4000K/5000K	030TW = 30/25/17 063TW = 63/50/36 108TW = 108/90/63 155TW = 155/125/90 250TW = 250/200/150/125	Univ = 120-347AC	P = avec photocell Vide = sans photocell	TR = Montage en étrier SF = Montage Slipfitter KN = Montage à rotule

Numéro de catalogue par exemple: PQ-FLX-CCTK-250TW-UNIV-P-KN

### CERTIFICATIONS



**PROJECTEUR**

PQ-FLX

**SPÉCIFICATIONS**

Modèles	30TW	63TW	108TW	155TW	250TW
Tension d'entrée	AC120-347V				
Lumens	5,100lm	9,765lm	17,280lm	24,025lm	37,500lm
Température de couleur (CCT)	(3000K / 4000K / 5000K) Sélectionnable				
Fréquence	50/60 Hz				
Dimmable	0-10V				
Boîtier	Aluminium moulé sous pression				
Montage	Montage à rotule Montage en étrier Montage sur adaptateur				
Options	Photocell (sur commande)				
Température de fonctionnement	-40° F (-40° C) à 113° F (45° C)				
Couleur de finition	Bronze foncé				
Certifications	cULus, DLC premium				
Garantie	5 ans				

# PROJECTEUR

PQ-FLX

## CAPACITÉ DE SÉLECTION DE LA CCT

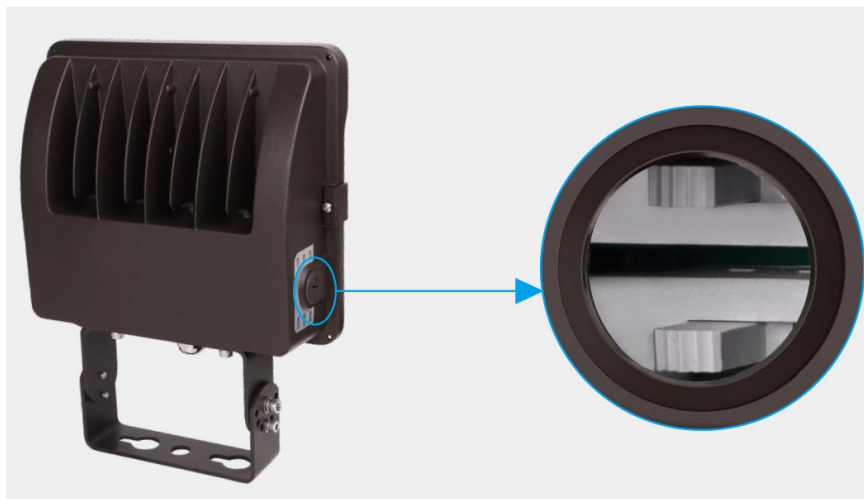

1  
2  
3

**Power Setting**

Réglage de puissance entre 30/25/17W, réglage par défaut à 30W. 63/50/36W, réglage par défaut à 63W. 108/90/63W, réglage par défaut à 108W. 155/125/90W, réglage par défaut à 155W.

3000K  
4000K  
5000K

**CCT Setting**

Réglage CCT entre 3000K/4000K/5000K, réglage par défaut à 5000K.

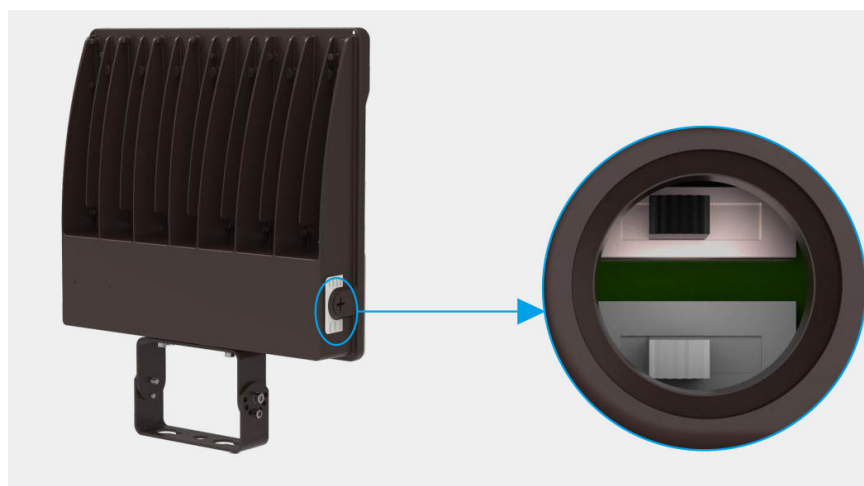

1  
2  
3  
4

**Power Setting**

Réglage de puissance entre 250/200/150/125W, réglage par défaut à 250W.

3000K  
4000K  
5000K

**CCT Setting**

Réglage CCT entre 3000K/4000K/5000K, réglage par défaut à 5000K.

**MONTAGE À ROTULE 1/2" NPSM**  
MODÈLES: 30TW & 63TW



**MONTAGE EN ÉTRIER**  
MODÈLES: 30TW / 63TW / 108TW / 155TW



**MONTAGE EN ÉTRIER**  
MODÈLES: 250TW



# PROJECTEUR

PQ-FLX

MONTAGE SLIPFITTER  
MODÈLE: 108TW & 155TW



MONTAGE SLIPFITTER  
MODÈLE: 250TW



## DONNÉES ÉLECTRIQUES

Modèle	Puissance	Courant (A)				
		Tension d'Entrée (V)				
		120	208	240	277	347
30TW	17	0.16	0.09	0.08	0.07	0.05
	25	0.23	0.13	0.12	0.10	0.08
	30	0.28	0.16	0.14	0.12	0.10
63TW	36	0.33	0.19	0.17	0.14	0.12
	50	0.46	0.27	0.23	0.20	0.16
	63	0.58	0.34	0.29	0.25	0.20
108TW	63	0.58	0.34	0.29	0.25	0.20
	90	0.83	0.48	0.42	0.36	0.29
	108	1.00	0.58	0.50	0.43	0.35
155TW	90	0.83	0.48	0.42	0.36	0.29
	125	1.16	0.67	0.58	0.50	0.40
	155	1.44	0.83	0.72	0.62	0.50
250TW	125	1.16	0.67	0.58	0.50	0.40
	150	1.39	0.80	0.69	0.60	0.48
	200	1.85	1.07	0.93	0.80	0.64
	250	2.31	1.34	1.16	1.00	0.80

# PROJECTEUR

PQ-FLX

## DIMENSIONS POUR LE MONTAGE

MONTAGE À ROTULE 1/2" NPSM	L × W × H
30TW	9.8x7.0x2.3 (inch) 250.1x177.0x57.3 (mm)
63TW	10.8x8.0x2.5 (inch) 275.1x202.2x62.3 (mm)

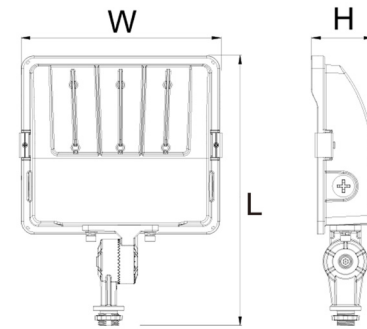

MONTAGE À ROTULE 1/2" NPSM

MONTAGE EN ÉTRIER	L × W × H
30TW	8.7x7.0x2.3 (inch) 220.5x177.0x57.3mm(mm)
63TW	9.7x8.0x2.5 (inch) 245.6x202.2x62.3(mm)
108TW	11.8x9.2x2.9 (inch) 300.3x232.6x73.6 (mm)
155TW	13.5x10.7x2.9 (inch) 342.3x272.6x73.6 (mm)
250TW	16.4x14.0x2.6 (inch) 416.7x354.5x66.6 (mm)

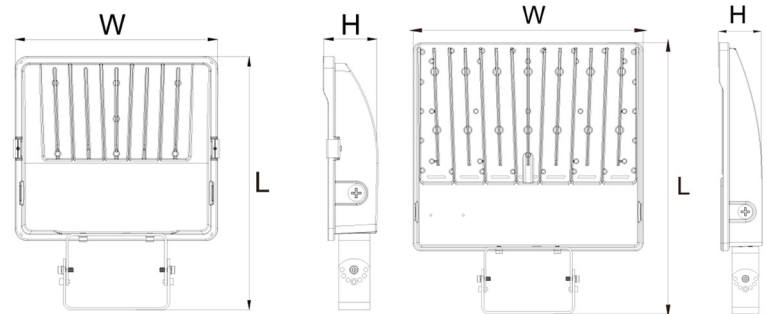

MONTAGE EN ÉTRIER

MONTAGE SLIPFITTER	L × W × H
108TW	15.3x9.2x2.9 (inch) 387.6x232.6x73.6 (mm)
155TW	16.8x10.7x2.9 (inch) 427.8x272.6x73.6 (mm)
250TW	19.8x14.0x2.6 (inch) 504.0x354.5x66.6 (mm)

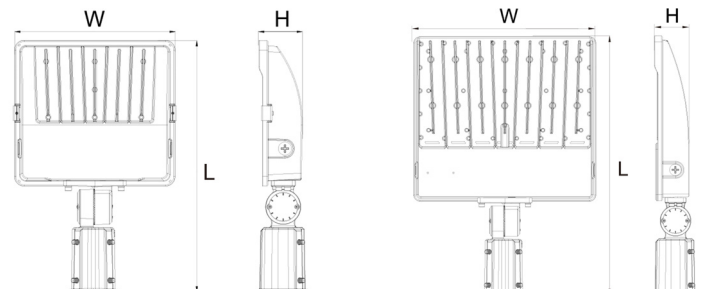

MONTAGE SLIPFITTER

# PROJECTEUR

PQ-FLX

## SCHÉMAS DE PERÇAGE

### MONTAGE À ROTULE 1/2" NPSM

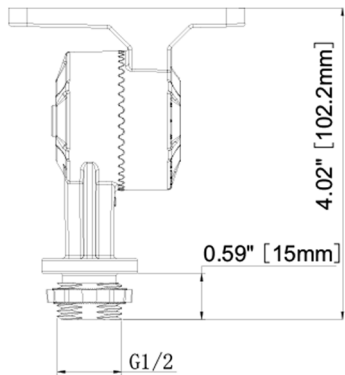

POUR 30TW & 63TW

### MONTAGE EN ÉTRIER

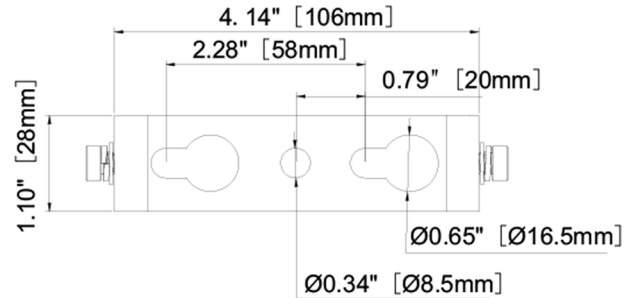

POUR 30TW & 63TW

### MONTAGE EN ÉTRIER

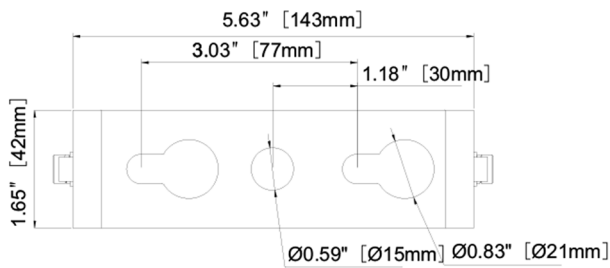

POUR 108TW / 155TW / 250TW

### MONTAGE SLIPFITTER

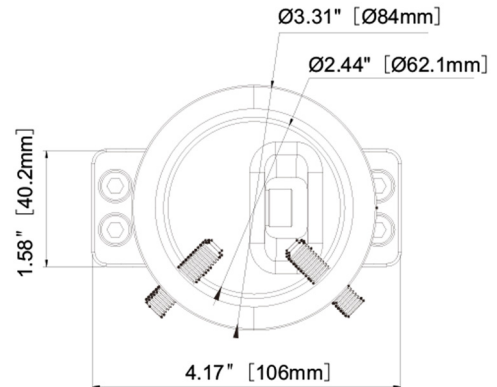

POUR 108TW / 155TW / 250TW

# PROJECTEUR

PQ-FLX

## ACCESSOIRES (EN OPTIONS)

	Photocell - Avec capot pare-soleil
	Kit de bouchon court (avec réceptacle) pour 250TW
	Kit photocell à verrouillage par rotation (avec réceptacle) pour 250TW

## PHOTOMÉTRIE

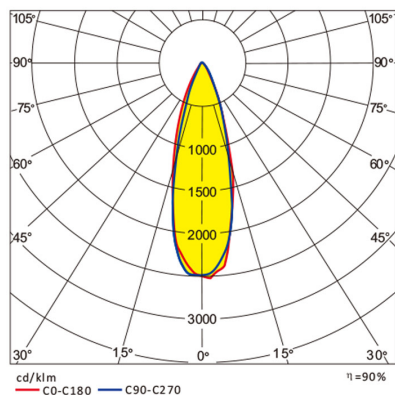

NEMA 4H4V  
250W

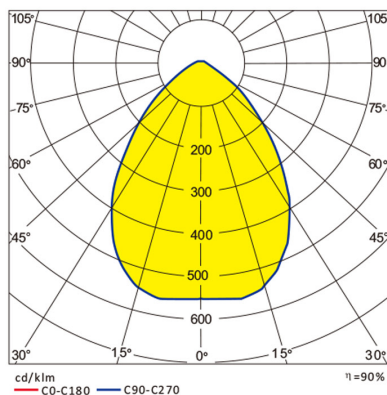

NEMA 6H6V  
250W

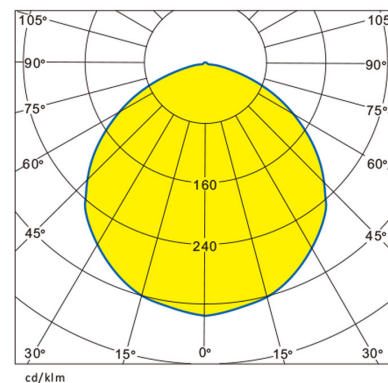

NEMA 7H7V  
30W~155W

## DONNÉES DE PERFORMANCE

Modèles	30TW	63TW	108TW	155TW	250TW
Puissance (W)	30/25/17	63/50/36	108/90/63	155/125/90	250/200/150/125
Lumens (lm)	5,100	9,765	17,280	24,025	37,500
Température de couleur (CCT)	(3000K / 4000K / 5000K) Sélectionnable				



# PROJECTEUR

PQ-FLX

## APPLICATIONS

